



EvenGLO Specification Sheet

Radiant Patio Heater

<u>SPECIFICATIONS</u>	<u>MODEL GA301</u>	<u>MODEL GA301H</u>
Volts	24 VAC	24 VAC
Amps	0.8	0.8
Control	Two-Stage Switch, Direct Spark	Two-Stage Switch, Direct Spark
Fuel	NG or LPG	NG or LPG
Operating Pressure NG	Min 6.5" W.C Max 14" W.C	Min 6.5" W.C Max 16" W.C
Operating Pressure LPG	Min 10.8" W.C Max 14" W.C	Min 10.8" W.C Max 14" W.C
High Fire NG	*53,000 BTU/H	*53,000 BTU/H
Low Fire NG	*46,000 BTU/H	*46,000 BTU/H
High Fire LPG	*47,000 BTU/H	*47,000 BTU/H
Low Fire LPG	*40,000 BTU/H	*40,000 BTU/H
Mounting Options	Vertical Pole	Overhead Suspension
Effective Range	*12' to 24' Radius	*12' to 24' Radius
Distance	*14' to 20' apart	*14' to 20' apart

*TYPICAL COVERAGE

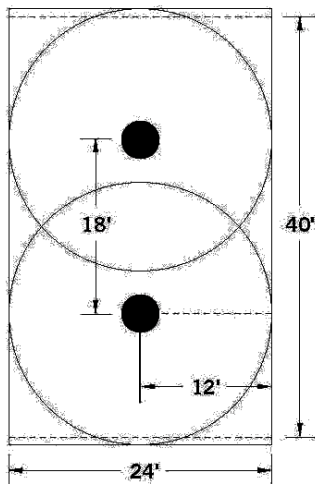

*Note: Ambient temperatures and wind conditions vary and will affect heater performance. To maximize layout distances, employ building walls, alcoves, fences and shrubbery lines as wind barriers.

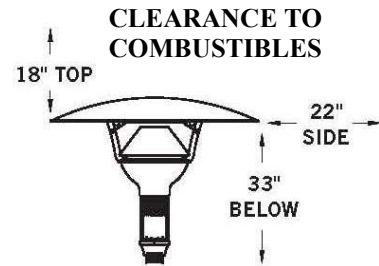
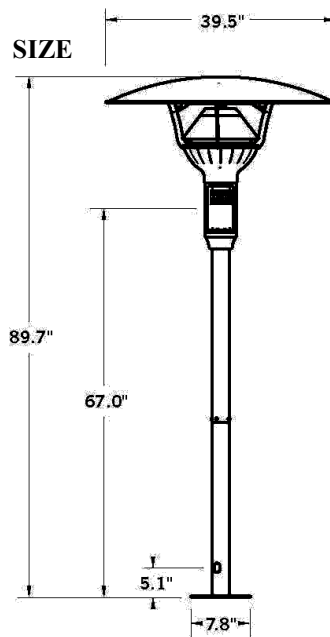

HANGING DIMENSIONS

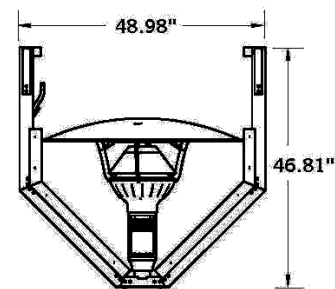

FEATURES

- Commercial grade construction engineered for extended rugged use
- Emitter warranty 5 years, controls and components 3 years
- **Heats larger area than conventional umbrella style heaters (up to 58% greater than comparative model)
- Two-Stage Switch (optional zoning) → Part# EE020
- Keeps more patrons comfortable per heater
- Exotic open flame "luau" torch design provides unique ambiance
- Engineered "double surface" reflector provides unmatched comfort circle

**Data Source: FSTC Report #5011.07.05