



EvenGLO Specification Sheet

Radiant Patio Heater

MODEL GA201M

<u>SPECIFICATIONS</u>	<u>E201PMS3</u>	<u>E201PMS4</u>	<u>E201PMB</u>
Finish	304 S/S	430 S/S	Powder Coated Black
Gas Manifold Pressure	11" W.C	11" W.C	11" W.C
Max. Inlet Gas Supply Pressure	250psi	250psi	250psi
Control	AA Battery 'Piezo' Ignition	AA Battery 'Piezo' Ignition	AA Battery 'Piezo' Ignition
Fuel	LPG	LPG	LPG
Variable Fire Rate (max)	*46,000 BTU/H	*46,000 BTU/H	*46,000 BTU/H
Wood & Concrete Securable	Yes	Yes	Yes
Wheels	Included	Included	Included
Beverage / Food Tray	Optional	Optional	Optional
Weight	120lbs	120lbs	120lbs
Effective Range	*12' to 24' Radius	*12' to 24' Radius	*12' to 24' Radius
Distance	*14' to 20' apart	*14' to 20' apart	*14' to 20' apart

*TYPICAL COVERAGE

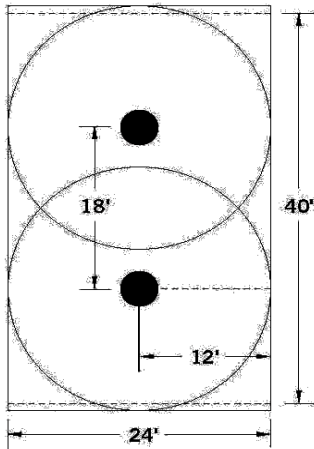

*Note: Ambient temperatures and wind conditions vary and will affect heater performance. To maximize layout distances, employ building walls, alcoves, fences and shrubbery lines as wind barriers.

SIZE

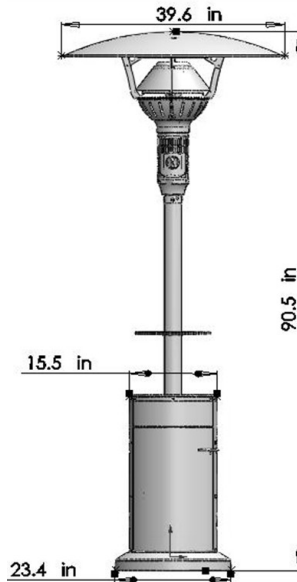

CLEARANCE TO COMBUSTIBLES

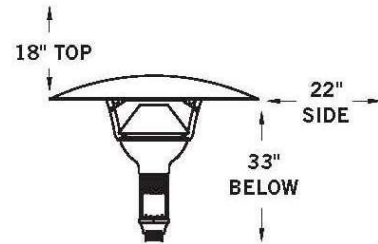

BALL BEARING WHEELS

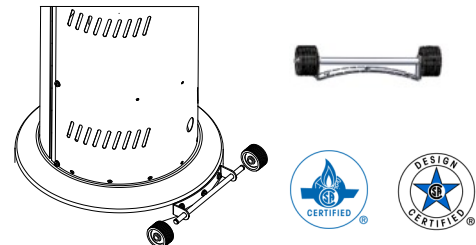

FEATURES

- Commercial grade construction engineered for extended rugged use
- Emitter warranty 5 years
- **Heats larger area than conventional umbrella style heaters (up to 58% greater than comparative model)
- AA Battery operated 'Piezo Ignition' dial
- Keeps more patrons comfortable per heater
- Exotic open flame "luau" torch design provides unique ambiance
- Engineered "double surface" reflector provides unmatched comfort circle

**Data Source: FSTC Report #5011.07.05